



Alpina

bicycle

EVO ²²⁻²³ **L**



Via Archimede, 485
47521 Cesena (FC)
ITALY
T. +39 0547 645699
F. +39 0547 645783
info@alpinabike.com



CATALOGO EVOJ 2022-23



INDICE

C1 TRK 28 ANTHEA MAN	4
C1 TRK 28 ANTHEA LADY	6
I1 CITY 28 ARIS MAN	10
I1 CITY 28 ARIS LADY	12
Q1 TRK 28 ATLANTA MAN	16
Q1 TRK 28 ATLANTA LADY	18
A1 CITY 28 ALFA LADY	24
A3 MONOTUBO ATHENA	26
A4 MONOTUBO AGORA	28





C1 TRK 28 ANTHEA MAN



Nero opaco | Oro perlato | Smeraldo
Matt black | Pearl gold | Emerald



TELAIO / FRAME	alloy 6061 mm 500
FORCELLA / FORK	Suntour NEX ML
GUARNITURA / CRANKSET	alloy 42 t
COMANDI / SHIFTER	st-ef 7v
CAMBIO POST / REAR DERAILL	Shimano RD-M310 altus
RUOTA LIBERA / FREEWHEEL	Shimano TY21 7 speed
MANUBRIO / HANDLEBAR	Over trk 28
PIANTONE / STEM	Alloy h.s. adjustable iso 4210
LEVE FRENO / BRAKE LEVEL	Logan Hidraulic brake
FRENI / BRAKES	Logan Hidraulic brake
LUCI / LIGHT	Spanninga GER
REGGISSELLA / SEATPOST	alloy
SELLA / SADDLE	Royal Essenza
MOZZI / HUB	alloy QR/QR 36H
COPERTURE / TYRES	Michelin Proteck 700x48 antipuncture
PEDALI / PEDALS	alloy
IMBALLO / BOX	190 - m3 0,35
DISPLAY	Oli-ebike LCD colored
MOTO	Oli-ebike central moto 60N
BATTERY	integrated battery 15ah (550 wh)

C1 ANTHEA MAN



C1 TRK 28 ANTHEA MAN



Nero opaco | Oro perlato | Smeraldo
Matt black | Pearl gold | Emerald



TELAIO / FRAME	alloy 6061 mm 460
FORCELLA / FORK	Suntour NEX ML
GUARNITURA / CRANKSET	alloy 42 t
COMANDI / SHIFTER	st-ef 7v
CAMBIO POST / REAR DERAILL	Shimano RD-M310 altus
RUOTA LIBERA / FREEWHEEL	Shimano TY21 7 speed
MANUBRIO / HANDLEBAR	Over trk 28
PIANTONE / STEM	Alloy h.s. adjustable iso 4210
LEVE FRENO / BRAKE LEVEL	Logan Hidraulic brake
FRENI / BRAKES	Logan Hidraulic brake
LUCI / LIGHT	Spanninga GER
REGGISELLA / SEATPOST	alloy
SELLA / SADDLE	Royal Essenza
MOZZI / HUB	alloy QR/QR 36H
COPERTURE / TYRES	Michelin Proteck 700x48 antipuncture
PEDALI / PEDALS	alloy
IMBALLO / BOX	190 - m3 0,35
DISPLAY	Oli-ebike LCD colored
MOTO	Oli-ebike central moto 60N
BATTERY	integrated battery 15ah (550 wh)

C1 ANTHEA LADY





SPORT ONE

Code	SPORTONE
Rated Power	250W
Rated Voltage	36V
Max Torque	60Nm
Internal Gear Stages	2
Weight	3,2Kg
Communication	UART
Fixing Holes Pattern	2x3 M8 proprietary pattern
Q-Factor	178mm
Chain-line	52mm (142mm/148mm boost)
Crank interface	ISIS
Chainring options	BCD 104 - 30/44T
Coaster brake option	Yes
Chain-guide and bashguard	Yes
Applications	City, Gravel, long-distance
Availability	Mass Production

DISPLAY HIGH vision



HIGH vision

Code	DISPHV
Screen Size	2"
Handlebar bracket	31,8 mm
Twilight Sensor	Yes
Remote Controller	Yes
Walk Mode	Yes, on remote
BT/ANT+ Connectivity	Q4 2021
Communication	CANBUS/UART
Custom logo at startup	Yes
Availability	Mass production

2" High-definition TFT display Packed in a slim and elegant design it seamlessly integrates with any handlebar. Thanks to its dualsided bracket that firmly holds it right in front of the stem, you can access any info at first sight.

On top of those common functionalities, the HIGH Vision features:

- Motor power output
- Rider power
- Automatic light switch
- Dark mode
- Gorilla-Glass® anti reflective screen
- IP68 certified



GHOST FULLY INTEGRATED

GHOST 540

Code	GHOST540
Pack	10S5P
Cell Type	18650
Cell Brand	BAK
Dimensions (mm)	411 x 63 x 85
Nominal Voltage	36V
Nominal Capacity	15Ah - 540Wh
Communication	Canbus
Weight	3.2Kg
Compliance EN15194:2017	Yes
Availability	Q1 2022

I1 CITY 28 ARIS MAN



Nero opaco | Blu Italia | Oro Perlato
Matt black | Italian blue | Pearl gold



TELAIO / FRAME	alloy 6061 mm 500 w/intern system battery
FORCELLA / FORK	steel 1 1/8
GUARNITURA / CRANKSET	PRW alluminio
COMANDI / SHIFTER	Shimano RS46 7s
CAMBIO POST / REAR DERAILL	Shimano TY300
RUOTA LIBERA / FREEWHEEL	Shimano Ty21 - 7 speed
MANUBRIO / HANDLEBAR	Alloy Iso 4210
PIANTONE / STEM	Alloy adjustable
LEVE FRENO / BRAKE LEVEL	alloy
FRENI / BRAKES	mechanical disk brake
LUCI / LIGHT	Buchel Ger
REGGISELLA / SEATPOST	alloy
SELLA / SADDLE	MTG aris
MOZZI / HUB	alloy disk
COPERTURE / TYRES	mitas 700x48 antipuncture
PEDALI / PEDALS	no slip
IMBALLO / BOX	190 - m3 0,35
DISPLAY	LCD 5 levels PAS
MOTO	rear moto 45N
BATTERY	battery indoor down tube 10,2ah (370 wh)

11 ARIS MAN



I1 CITY 28 ARIS LADY



Nero opaco | Blu Italia | Oro Perlato
Matt black | Italian blue | Pearl gold



TELAIO / FRAME	alloy 6061 mm 460 w/intern system battery
FORCELLA / FORK	steel 1 1/8
GUARNITURA / CRANKSET	PRW alluminio
COMANDI / SHIFTER	Shimano RS46 7s
CAMBIO POST / REAR DERAILL	Shimano TY300
RUOTA LIBERA / FREEWHEEL	Shimano Ty21 - 7 speed
MANUBRIO / HANDLEBAR	Alloy Iso 4210
PIANTONE / STEM	Alloy adjustable
LEVE FRENO / BRAKE LEVEL	alloy
FRENI / BRAKES	mechanical disk brake
LUCI / LIGHT	Buchel Ger
REGGISELLA / SEATPOST	alloy
SELLA / SADDLE	MTG aris
MOZZI / HUB	alloy disk
COPERTURE / TYRES	mitas 700x48 antipuncture
PEDALI / PEDALS	no slip
IMBALLO / BOX	190 - m3 0,35
DISPLAY	LCD 5 levels PAS
MOTO	rear moto 45N
BATTERY	battery indoor down tube 10,2ah (370 wh)

1 ARIS LADY





BTRHL-3610

PACK:	10S2P
CELL TYPE:	21700
CELL BRAND:	SAMSUNG
DIA.:	582.3L * 48.4W * 48.1H MML (including controller)
NOMINAL CAPACITY:	10.2 Ah - 370 Wh
COMMUNICATION:	NA
WEIGHT :	1.76KG (battery only including cells , w/o controller)
COMPLIANCE EN15194/2017:	YES



Rear Motor DGW07C-MD

Voltage	36V
Design	Brushless
Wattage	250W,255RPM
Motor Type	Brushless Gear Hub Motor
SKU	MINI-DB-R
Type	DGW07
Specification	16-28in 36(Holes)
Rated Power	250W
Rated Voltage	36V
Fork size	135mm



MODEL:	TC490
SCOPE OF APPLICATION:	EN15194
VOLT:	36
PAS LEVELS.:	N°5
DIM:	mm 44,4 x 94,7
WATERPROOF GRADE:	IP65

Q1 TRK 28 ATLANTA MAN



Nero opaco | Ghiaia | Blu zaffiro
Matt black | Gravel | Sapphire Blue



TELAIO / FRAME	alloy 6061 mm 480
FORCELLA / FORK	suspension fork ML
GUARNITURA / CRANKSET	PRW alluminio
COMANDI / SHIFTER	Shimano RS-46 7v
CAMBIO POST / REAR DERAILL	Shimano TY300
RUOTA LIBERA / FREEWHEEL	shimano Ty21 - 7 speed
MANUBRIO / HANDLEBAR	ALLOY Iso 4210
PIANTONE / STEM	ALLOY adjustable
LEVE FRENO / BRAKE LEVEL	alloy
FRENI / BRAKES	mechanical disk brake
LUCI / LIGHT	buchel ger
REGGISELLA / SEATPOST	alloy
SELLA / SADDLE	alpina soft
MOZZI / HUB	alloy disk
COPERTURE / TYRES	mitas 700x48 antipuncture
PEDALI / PEDALS	no slip
IMBALLO / BOX	190 - m3 0,35
DISPLAY	LCD 5 levels PAS
MOTO	rear moto 45N
BATTERY	integrsted battery 14ah (500wh)

Q1 ATLANTA MAN



Q1 TRK 28 ATLANTA LADY



Nero opaco | Ghiaia | Azzurro
Matt black | Gravel | Light Blue



TELAIO / FRAME	alloy 6061 mm 460
FORCELLA / FORK	suspension fork ML
GUARNITURA / CRANKSET	PRW alluminio
COMANDI / SHIFTER	Shimano RS-46 7v
CAMBIO POST / REAR DERAILL	Shimano TY300
RUOTA LIBERA / FREEWHEEL	shimano Ty21 - 7 speed
MANUBRIO / HANDLEBAR	ALLOY Iso 4210
PIANTONE / STEM	ALLOY adjustable
LEVE FRENO / BRAKE LEVEL	alloy
FRENI / BRAKES	mechanical disk brake
LUCI / LIGHT	buchel ger
REGGISELLA / SEATPOST	alloy
SELLA / SADDLE	alpina soft
MOZZI / HUB	alloy disk
COPERTURE / TYRES	mitas 700x48 antipuncture
PEDALI / PEDALS	no slip
IMBALLO / BOX	190 - m3 0,35
DISPLAY	LCD 5 levels PAS
MOTO	rear moto 45N
BATTERY	integrsted battery 14ah (500wh)

Q1 ATLANTA LADY



Pacco-batteria AQL-BI03

Modelli: Q1 ATLANTA MAN/LADY

Manuale d'uso

Installare il pacco batteria

Innanzitutto, controllare lo status del fanale nella batteria. Ricaricare la batteria appena la Potenza è bassa e se è piena, usarla normalmente.

Premere "OFF" nella batteria.

Inserite la batteria nella giusta posizione del supporto.

Girare la chiave della presa alla posizione "LOCK".

Inserire la batteria nella posizione "ON" e controllare la qualità elettrica. Usare la batteria solo in stato normale; altrimenti prego di contattare il proprio fornitore.

Nota: Spegnerne la batteria per risparmiare la Potenza in caso di non utilizzo.

Togliere la batteria

Premere OFF "sulla batteria.

Girare la chiave della presa su "OPEN".

Togliere la batteria dal supporto attentamente.

Nota: Tenere la batteria in un luogo asciutto lontano dai contatti di agenti atmosferici.

Uso della batteria

1. Inizialmente caricare la batteria pienamente.
2. Inserire la batteria nella cornice e chiuderla.
3. Accendere la batteria e controllare lo stato delle luci o il LED display.
4. Prego di spegnere la batteria dopo l'uso. (girare l'interruttore su "OFF")
5. La batteria può essere usata tra la temperatura -20~50°C. La gamma della bici può essere ridotta se la temperatura non è tra -10~40°C.
6. Lontano da calore, acqua ed incendio. La temperatura di conservazione migliore è tra -10~40°C in luoghi asciutti, puliti e ventilati.
7. Non ridurre il circuito dell'elettrodo positive e negativo della batteria.
8. Caricare la batteria almeno 4 mesi.

Avvertenza! È importante usare le parti di sostituzione in maniera adeguata alla sicurezza. La batteria è un unico componente e deve essere approvata da AQL.



Caratteristiche tecniche del caricatore

ELEMENTI	SPECIFICHE
Numero di modello	DZL(M)3710A0
Voltaggio	100-240Vac
Frequenza	47-63Hz
Voltaggio d'uscita	41.9±0.2V
Corrente di carica (max.)	2.0±0.2A
Tempo di carica	6.5hrs (468Wh battery)
Temperatura di funzionamento	0°C - 40°C
Temperatura di conservazione	-20°C - 65°C
Peso, appross.	0.8Kg



Carica pacco batteria

Avvertenza! Prima di caricare, prestare attenzione che il sistema sia spento e mai girare l'interruttore su on e off durante la carica. Questo impedisce indesiderate attivazioni del Sistema. Durante la carica, non lasciare il pacco batteria in zone bagnate onde evitare rischi di elettroshock.

Il pacco batteria può essere caricato quando è installata nella bici (quando la potenza della bici è "OFF") o quando è rimosso dalla bici.

Prestare attenzione che la Potenza principale è spenta o la batteria tolta dalla bici prima della ricarica.

L'etichetta della ricarica contiene informazioni su tutte le specifiche e voltaggio d'entrata, d'uscita, polarità e avvertenze dell'uso. È importante seguire le istruzioni di questo manuale e l'etichetta del carica batteria.

Istruzioni:

1. Innanzitutto, collegare il carica batterie sulla zona adeguata della batteria.
2. Inserire il carica batteria sulle prese principali di potenza 220 V.
3. L'operazione di ricarica inizia e l'indicatore di luce sul carica batteria è illuminato.
4. Quando la batteria è carica, approssimativamente circa dopo 6 ore dallo stato completamente scarico, la luce da rossa diventa verde.

Avvertenze:

1. Ricaricare la batteria quando nel display è visibile che lo stato di luce è "vuoto".
2. In caso la batteria si scarichi completamente durante l'utilizzo dell'E-bike, il display spegnerà automaticamente il motore. Girando la chiave di avvio a "OFF" e poi "ON", il motore si accenderà nuovamente, ma solo per pochi minuti. Non girare di continuo la chiave tra "ON" e "OFF" per evitare seri danni alla batteria.

LED nel carica batteria

- Luce rossa indica "da caricare"
- Luce verde indica "caricato completamente" o
- No luce vuol dire "sconnesso dalla presa a muro"

5. Disconnettere poi la batteria e mettere il carica batteria in un luogo al sicuro.



Status	
1 light	0% - 20%
1, 2 light	15% - 40%
1, 2, 3 light	35% - 70%
1, 2, 3, 4 light	65% - 90%
1, 2, 3, 4, 5 light	85% - 100%





A1 CITY 28 ALFA LADY



Nero opaco | Ghiaia | Menta
Matt black | Gravel | Mint



TELAIO / FRAME	alluminio omologato e-bike
FORCELLA / FORK	suspension fork
GUARNITURA / CRANKSET	PRW alluminio
COMANDI / SHIFTER	Shimano RS-36 7v
CAMBIO POST / REAR DERAILL	Shimano Ty300
RUOTA LIBERA / FREEWHEEL	Shimano TY21
MANUBRIO / HANDLEBAR	ALLOY Iso 4210
PIANTONE / STEM	alloy adjustable
LEVE FRENO / BRAKE LEVEL	alloy
FRENI / BRAKES	v/brake Promax omologate ebike
LUCI / LIGHT	Buchel Ger
REGGISSELLA / SEATPOST	alloy
SELLA / SADDLE	smp
MOZZI / HUB	alloy
COPERTURE / TYRES	700x42 brown ebike
PEDALI / PEDALS	no slip
IMBALLO / BOX	190 - m3 0,35
DISPLAY	LCD 5 levels PAS
MOTO	motore posteriore 36V 250w
BATTERY	batteria da 15,6ah (570 wh)

A1 ALFA



A3 MONOTUBO ATHENA



Nero opaco | Ghiaia | Menta
Matt black | Gravel | Mint



TELAIO / FRAME	alluminio omologato e-bike
FORCELLA / FORK	suspension fork
GUARNITURA / CRANKSET	PRW alluminio
COMANDI / SHIFTER	shimano RS-36 6v
CAMBIO POST / REAR DERAILL	Shimano tx200
RUOTA LIBERA / FREEWHEEL	Shimano TY206v
MANUBRIO / HANDLEBAR	alluminio ISO4210
PIANTONE / STEM	alloy adjustable
LEVE FRENO / BRAKE LEVEL	alloy
FRENI / BRAKES	v/brake Promax omologate ebike
LUCI / LIGHT	Buchel Ger
REGGISELLA / SEATPOST	alloy
SELLA / SADDLE	alpina soft
MOZZI / HUB	alloy
COPERTURE / TYRES	700x42 mitas antipuncture
PEDALI / PEDALS	no slip
IMBALLO / BOX	190 - m3 0,35
DISPLAY	LCD 5 levels PAS
MOTO	motore posteriore 36V 250w
BATTERY	batteria da 11ah (400wh)

A3

ATHENA

28



A4 MONOTUBO AGORA



Nero opaco | Ghiaia | Menta
Matt black | Gravel | Mint



TELAIO / FRAME	alluminio omologato e-bike
FORCELLA / FORK	suspension fork
GUARNITURA / CRANKSET	PRW alluminio
COMANDI / SHIFTER	shimano RS-36 6v
CAMBIO POST / REAR DERAILL	Shimano tx200
RUOTA LIBERA / FREEWHEEL	Shimano TY206v
MANUBRIO / HANDLEBAR	alluminio ISO4210
PIANTONE / STEM	alloy adjustable
LEVE FRENO / BRAKE LEVEL	alloy
FRENI / BRAKES	v/brake Promax omolgate ebike
LUCI / LIGHT	Buchel Ger
REGGISELLA / SEATPOST	alloy
SELLA / SADDLE	alpina soft
MOZZI / HUB	alloy
COPERTURE / TYRES	700x42 mitas antipuncture
PEDALI / PEDALS	no slip
IMBALLO / BOX	190 - m3 0,35
DISPLAY	LCD 5 levels PAS
MOTO	motore posteriore 36V 250w
BATTERY	batteria da 11ah (400wh)

A4 AGORA 26



Modelli: A1 15.6 Ah - A3, A4 11 Ah

Specifications

Rated voltage	36 V
Com. Protocol	UART
BMS	Smart BMS
Voltage scope (V)	31-42V
Charge mode	CC-CV (3 pin Pro-Movec charger)
Operation temperature charge	0°C -45°C
Backlight light	Yes



Battery options

Part No.	Name	Capacity
50637-BL-C	CAR6/2	8,8Ah, 36V, 316Wh
50663-BL-C	CAR6/2	12,8Ah, 36V, 482Wh
50638-BL-C-36V	CAR6/2-XL	11,0Ah, 36V, w/light, 396Wh
50774-BL-C-36V	CAR6/2-XL	13,2Ah, 36V, w/light, 415Wh
50775-BL-C-36V	CAR6/2-XL	15,6Ah, 36V, w/light, 562Wh
50776-BL-C-36V	CAR6/2-XL	17,4Ah, 36 w/light, 626Wh

Mounting parameter

Position	Carrier
Weight (kg)	2,6-3,1
Controller position	Carrier / center
Carrier	Optional
Charger	3 pin Pro-Movec charger

Tests & certifications

IP	IP 65
Certifications	CE / EN 15194 ROHS / REACH UN 38,3, MSDS

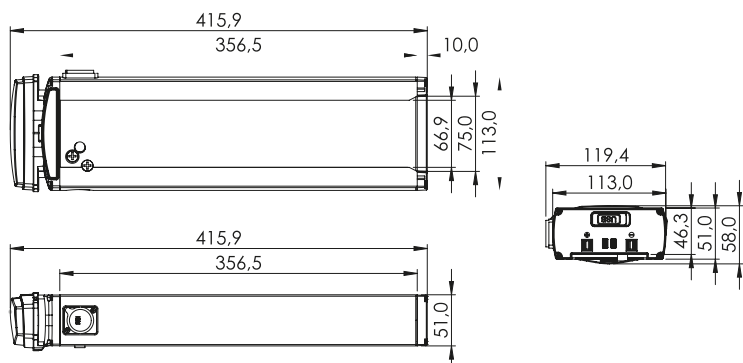

EPAC ACCORDING TO EN15194 25Km/h 250W

CONFORME AUX EXIGENCES DE SECURITE



Specifications

Position	Rear
Freewheel	Yes
Rated voltage	36 V
Rated power	250 W
Max. support bike speed	25 km/h
Max torque	40 Nm
Efficiency	Min. 80 %
Walk assist function	Yes
Color	Black/silver
Weight	2,9 kg
Operation temperature	Max. 120°
Max RPM	250 RPM
Wheel speed sensor	Integrated
Type	BLDC w. hall sensor



Function

Compatible brake type	Disc / V-brake
-----------------------	----------------

Tests & Certifications

IP classification	IP54
Certifications	CE / EN 15194 / ROHS

Mounting parameters

Fork width	135 mm
Axle diameter	Ø12 mm
Slot width	10 mm

Cables & connector

Cable length	220 mm
Connector	IP66 Plug

Spoke specifications

Flange width	40 mm
Spoke hole center-center	128 mm
Spoke hole diameter	Ø3 mm

Further specifications

Compatible wheel size	26"-29"
Rear sprocket	Cassette Shimano 8, 9, 10 speed

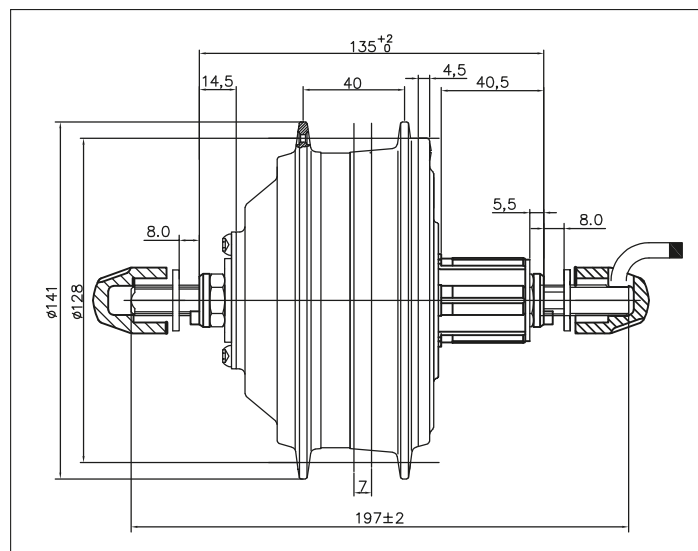





FABBRICA ITALIANA



Via Archimede, 485

47521 Cesena (FC)

ITALY

T. +39 0547 645699

F. +39 0547 645783

info@alpinabike.com

